

**INSTALLATION & USER INSTRUCTIONS**

Thank you for purchasing this Whale® product.

For over 40 years Whale® has led the way in the design and manufacturer of freshwater and waste systems including:- plumbing, faucets, showers and pumps for low voltage applications. The company and its products have built a reputation for quality, reliability and innovation backed up by excellent customer service.

For information on our full product range visit: [www.whalepumps.com](http://www.whalepumps.com)

**CONTENTS**

1. Principles of Operation
2. Specification
3. Application
4. Warnings
5. Parts List
6. Instructions for Installation
7. Instructions for Use
8. Maintenance
9. Trouble Shooting
10. Winterising
11. Service Support Details
12. EU Declaration of Conformity
13. Patents and Trademarks
14. Warranty

**LIST OF IMAGES**

- |         |                                |
|---------|--------------------------------|
| Fig. 1  | Components drawing             |
| Fig. 2  | Installation                   |
| Fig. 3  | Dimensions – top view          |
| Fig. 4  | Dimensions – side view         |
| Fig. 5  | Dimensions – front view        |
| Fig. 6  | Flue locating diagram          |
| Fig. 7  | Floor construction and cut out |
| Fig. 8  | Positioning the heater         |
| Fig. 9  | Securing the heater            |
| Fig. 10 | Attaching flues                |
| Fig. 11 | Secure flue brackets           |
| Fig. 12 | Connect to gas supply          |
| Fig. 13 | Fitting hot air ducts          |
| Fig. 14 | Tee fitting orientation        |
| Fig. 15 | Fitting cold air ducts         |
| Fig. 16 | Insert control panel           |
| Fig. 17 | Secure control panel           |
| Fig. 18 | Installed control panel        |
| Fig. 19 | Connect 12V to interface plate |
| Fig. 20 | Mains electrical connection    |
| Fig. 21 | Completed installation         |
| Fig. 22 | Control panel                  |

## 1. PRINCIPLES OF OPERATION

The Whale® 4kW Space Heater is an underfloor gas and electric blown air space heater. Nominal heat input is 2.9kW on gas and 2kW on mains electric. The 4kW Space Heater features a boost setting which varies the heat output depending on the temperature of the vehicle. It continually checks the temperature to establish the best settings to use, and is capable of using 2.9kW gas and up to 1kW electric simultaneously to provide the best available output. The compact design provides versatility in installation locations and it needs only minimal maintenance. The vehicle's internal temperature is set by a room controller which can be manually adjusted to a wide range of temperature settings or to warm weather ventilation.

**Read the following carefully before installation**

## 2. SPECIFICATION

Model SH4312B

Maximum dimensions: Height: 185mm, Width: 306mm, Length: 817mm

Countries of Destination: AT, BE, BG, CY, CZ, DE, DK, EE, FI, FR, GB, GR, HU, HR, IS, IT, LT, LU, LV, MT, NL, NO, PL, PT, RO, SE, SI, SK, TR

Weight: 10.9kg

Gas: Butane/Propane 30mbar - CAT I<sub>3B/P</sub> (30)  
Note: For use in road vehicles (caravans and motorhomes) only

Gas Consumption (M) 220g/hr

Classification of Heater: Type: C<sub>53</sub> (Fanned) Normal Installation

Nominal Heat Input on Gas: 2.9Kw  
Nominal Heat Input on Electric: 2.0kW  
Max Heat Input on Dual/ Boost: 3.9kW

Mains Electric:

Nominal voltage: 230V a.c. 50Hz  
Power options: 500/1000/2000W  
Maximum current a.c.: 9 Amps

Battery Supply

Nominal voltage: 12V d.c.  
Operating range: 10.0V d.c. min. to 15V d.c. max.  
Maximum current d.c. gas operation: 1.7 Amps (0.01Amps on standby)  
Maximum current d.c. electric operation: 2.2 Amps (0.01Amps on standby)  
Maximum current d.c. dual operation: 2.7 Amps

Dry Storage Temperature: -20°C to 70°C  
Hot Air Duct Diameter: 60mm ID  
Flue Diameter: 22mm ID

Maximum Exhaust Flue Length: 2m  
Minimum Exhaust Flue Length: 0.75m  
Maximum Combustion Air Flue Length: 2m  
Minimum Combustion Air Flue Length: 0.75m

Ensure that the position allows access for servicing the Space Heater and that there is a minimum of 25mm distance around the heater to adjacent walls when mounted inside the vehicle. For use in road vehicles only, i.e. caravans and motorhomes. Not suitable for caravan holiday homes i.e. mobile homes or static caravans.

Whale's policy is one of continuous improvement and we reserve the right to change specifications without prior notice.

### 3. APPLICATION

The Whale 4kW Space Heater has been designed for caravan and motorhome applications for typical recreational use. It is only suitable for use in road vehicles, i.e. caravans and motorhomes, but is not suitable for caravan holiday homes, i.e. mobile homes or static caravans. The heater is designed to be installed with a ducted hot air system.



**Do not** operate the appliance while the vehicle is in motion.

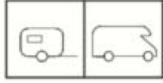

This symbol indicates that this appliance is suitable for use in Leisure Accommodation Vehicles.



This symbol indicates that this appliance is **not** suitable for use in boats.

### 4. WARNINGS



**Observe all warnings.**

In the unlikely event of leaks in the gas system, or if there is a smell of gas:

- Extinguish all naked flames
- Do not operate any electrical switches
- Turn off all gas appliances
- Open windows and doors for ventilation
- Do not smoke
- Shut off gas connection

Get the system thoroughly checked by a registered gas engineer at a Whale® Approved Service Centre / Technician.

The space heater **must not** be operated in the following situations:

- When refuelling the vehicle, the vehicle towing the caravan, or other appliances.
- When the vehicle in which the heater is installed is in motion.
- When the vehicle in which the heater is installed is in a confined space such as a garage.

This appliance is not intended for use by persons (including children) with reduced physical, sensory or mental capabilities, or lack of experience and knowledge, unless they have been given supervision or instruction concerning use of the appliance by a person responsible for their safety. Children should be supervised to ensure that they do not play with the appliance.

Ensure that a minimum of one of the hot air outlet vents is permanently open on each duct branch. This hot air vent should be the furthest from the Space Heater.

Any alteration to the appliance, including flue components, use of non-Whale® spare parts/accessories and non-observation of the installation and operation instructions shall lead to cancellation of the warranty and exclusion of liability claims and results in it becoming illegal to use the appliance.

Please note that incorrect installation, misuse or use of non-original Whale® parts may invalidate the warranty. It also becomes illegal to use the appliance if incorrectly installed, and in some countries this even makes it illegal to use the vehicle.

When operating using gas, the combustion air inlet flue and outlet flue for the products of combustion (exhaust flue) shall never be obstructed. They should be checked regularly, and if necessary cleaned by the user (e.g. in winter, snow **must** be removed from the combustion outlet and air intake).

Where the open end of the exhaust flue terminates, three sides of the under-floor space **must be** kept open and not obstructed, and **must not** contain through floor ventilation openings.

The heater, its gas supply, and flues for the products of combustion are to be inspected in accordance with national regulations or if these do not exist, the manufacturer's recommendations, however, it is advised that this should be done at least annually.



**WARNING:** Before obtaining access to the terminals, **all supply circuits** must be disconnected. The space heater and control panel come complete with electrical connectors fitted.

The heater **must** be installed in-line with a 5 Amp automotive fuse.

**Please note:** The heater and ducts will become hot. Avoid anything directly touching the heater or ducts.

## 5. PARTS LIST

The Whale® Space Heater kit contains:

	SH4312B
Space heater	1
Warranty registration card	1
Instruction manual including installation templates	1

Please note that the Whale® Space Heater requires a separate flue kit for installation. Flues are available in lengths of 0.75m to 2m.

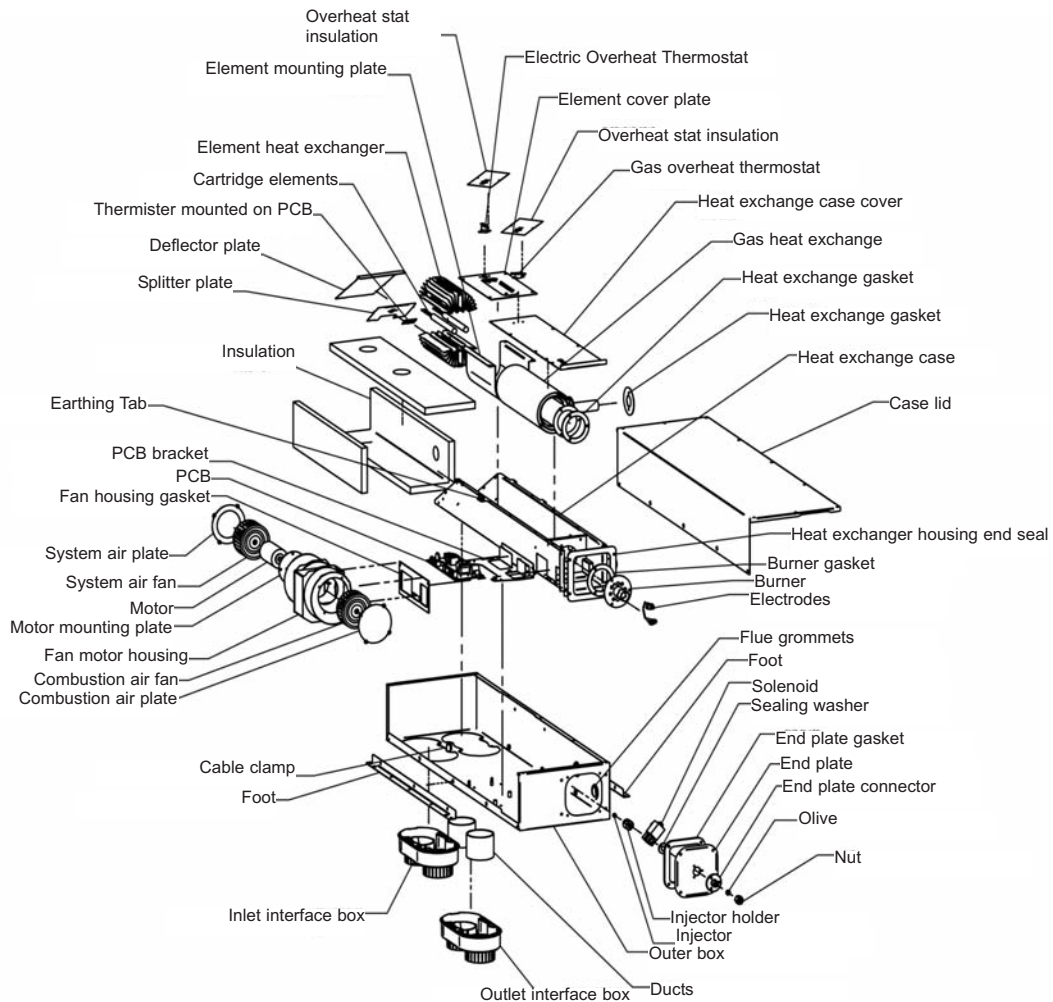

Fig. 1 - Components Drawing

## 6. INSTRUCTIONS FOR INSTALLATION

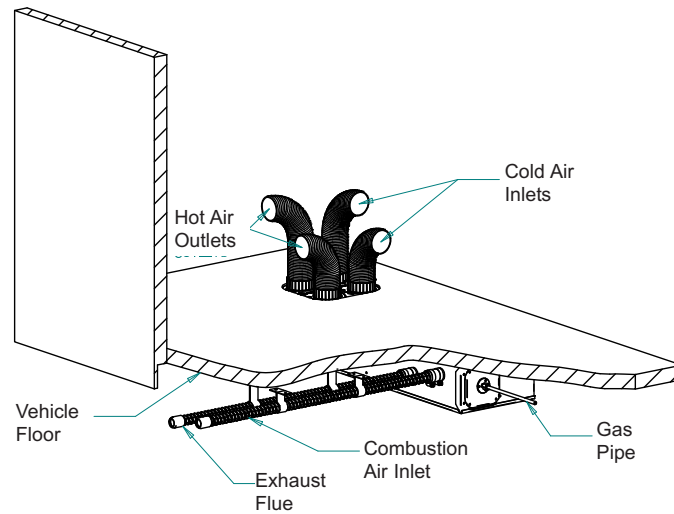

Fig. 2 - Installation

The Whale® Space Heater is installed under the floor of the caravan as shown in Fig. 2

### To the fitter:

Installation and servicing of this appliance **must only** be carried out by competent persons registered with the Gas Safe Register (GB) or the relevant national organisation, in accordance with the relevant regulatory and safety requirements.

Before installation, ensure the appliance has been supplied in good condition and if damaged do not install.

A competent person **must** install the appliance in accordance with the appliance installation instructions. This appliance is for use with LPG (see appliance data plate) and mains electricity (230V a.c.). Check that the product is suitable for the intended application, in particular the installer must check the compatibility of the data plate information with the LPG supply requirements of the vehicle. Follow these installation instructions and ensure all relevant personnel read the points listed below. Also ensure that these operating instructions are passed on to the end user.

**Please note:** The appliance should **only** be installed in accordance with any relevant regulations in the country where the appliance is installed. For this appliance in Europe the standard is BS EN 1949:2002 "Specification for the installation of LPG systems for habitation purposes in leisure accommodation vehicles and in other road vehicles".

**Please note:** Ventilation must comply with relevant national and/or local requirements.

## DIMENSIONS

### In vehicle installation

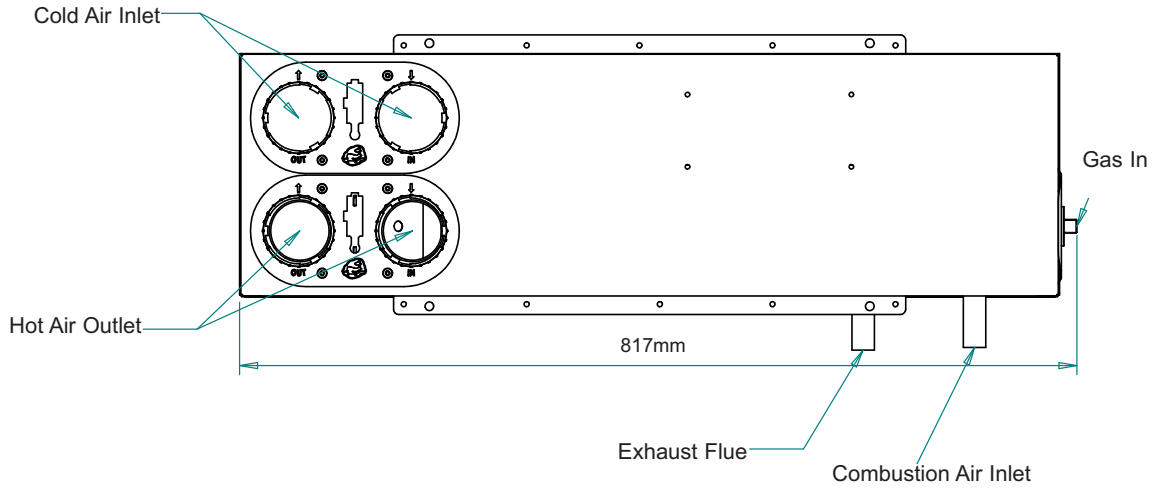

Fig. 3 - Dimensions Top View

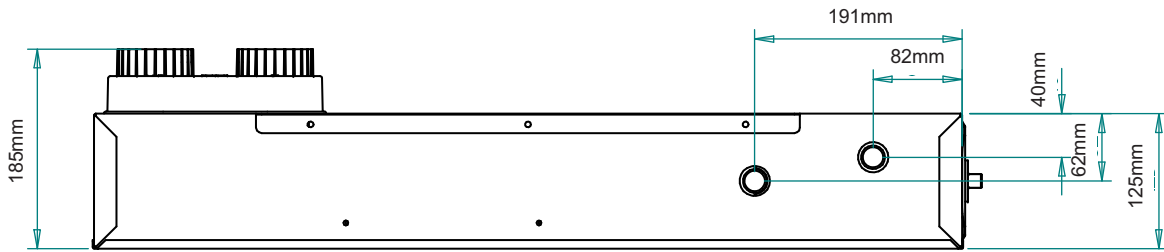

Fig. 4 - Dimensions - Side View

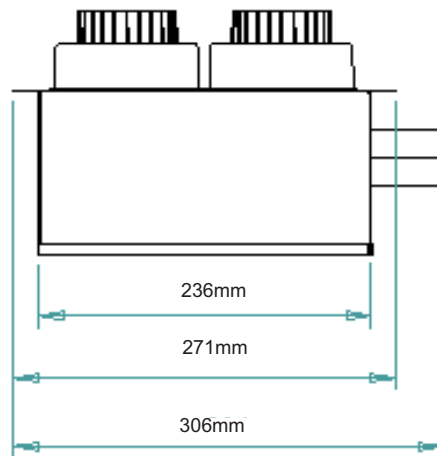

Fig. 5 - Dimensions Front View

## Step 1: Find Suitable Location for Space Heater Installation

### Consider the following points:

- i. For weight distribution in caravans, it is best to position the Space Heater as near to the axle as possible. You should avoid (where possible) locating at the very rear and preferably avoid the very front.
- ii. The heater should be positioned within the chassis members and close to the axle to help protect the appliance.
- iii. Please note: The heater, ducts and flues will become hot. Avoid anything directly touching these.
- iv. Ensure the position allows access for servicing the Space Heater and that there is a minimum of 25mm distance around the heater to adjacent walls.
- v. The hot air outlet of the heater is to be fitted to the hot air ducting system. The heater should be positioned to minimise the amount of ducting required and sharp bends in the ducting should be avoided.
- vi. In selecting the position of the Space Heater, ensure that the exhaust flue and combustion air inlet flues can be installed avoiding all chassis members and gas pipes etc. that are located underneath the floor.
- vii. The open end of the exhaust flue **must not** be fitted at the side of the caravan / motorhome where an awning may be fitted. It is thus preferable to install the heater on the opposite side of the caravan / motorhome to avoid routing the exhaust flue to the far side of the caravan / motorhome.
- viii. Only Whale® supplied flue components are permitted to be used. The open end of either flue **must not** be positioned within 300mm of a refuelling point or fuel tank breather outlet or any ventilator from the fuel system(s). The exhaust flue must not be fitted within 300mm of a ventilator for the living space or an opening part of a window. The open end of the exhaust flue must be positioned at least 500mm from the open end of the combustion air flue and be pointing in the same direction. The exhaust flue **must** be positioned at the side or end of the caravan / motorhome. The exhaust flue can only be positioned vertically below an opening part of a window if the appliance is fitted with an automatic shut-off device, to prevent operation when the window is open.

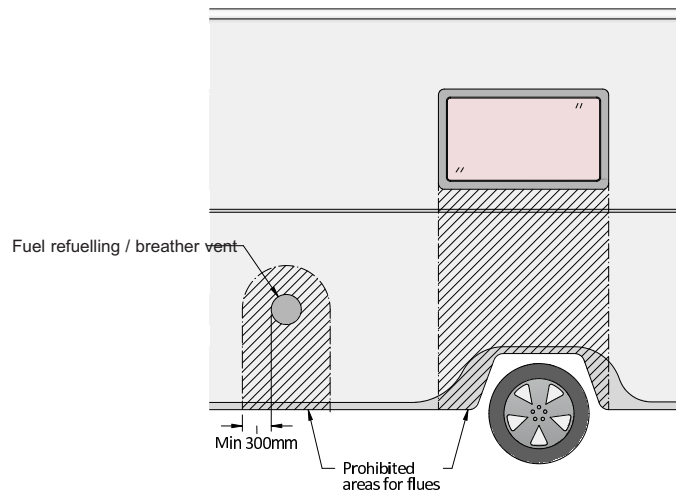

Fig. 6 - Flue Locating Diagram

- ix. The combustion air inlet flue can be terminated underneath the vehicle. The open end of it must be at least 500mm away from the open end of the exhaust flue, and pointing in the same direction. Take care to ensure that both flues have a slight downward slope from as close to the heater as possible to prevent any possibility of water traps. Ensure that neither the exhaust nor the combustion air inlet flues are terminated in an under-floor box section.
- x. The minimum length of the exhaust flue is 0.75m, and maximum length 2m. The minimum length of the combustion air inlet flue inlet must be 0.75m, and maximum length 2m.
- xi. When operating using gas, the combustion air inlet flue and outlet openings for the products of combustion (exhaust flue) **must not** be obstructed. They should be checked regularly, and if necessary cleaned by the user (e.g. in winter, snow shall be removed from the exhaust flue and combustion air inlet flue).

- xii. Where the open end of the exhaust flue terminates, three sides of the under-floor space **must** be kept open and not obstructed, and **must not** contain through-floor ventilation openings.
- xiii. The heater, its gas supply, ducting and flues **must** be inspected in accordance with national regulations or if these do not exist, the manufacturer's recommendations, however, it is advised that this should be done at least every year.
- xiv. The heater **must not** be used when the vehicle is in motion.

**Step 2: Heater location**

For installation, the floor of the vehicle should be manufactured as per the Fig. 7. It is important that wooden batons are incorporated in the floors construction to allow the bolts to be fitted through the batons in the floor. Screws may also be used for additional support, but it is recommended to use 4 through-floor bolts for securing the heater.

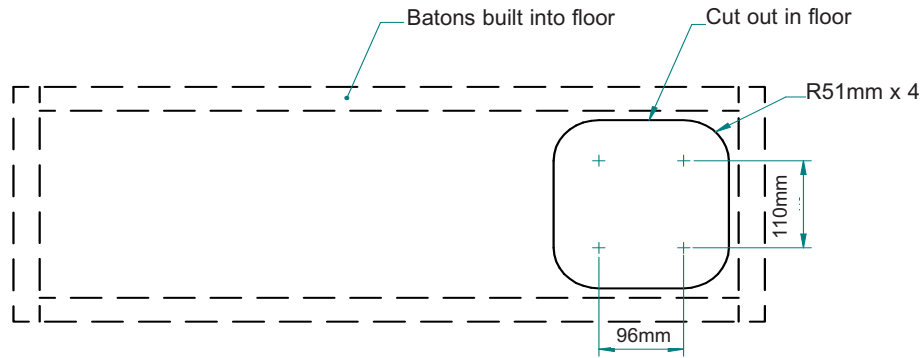

Fig. 7 - Floor Construction and Cut Out

Locate the heater in the correct position so that the brackets are aligned with the batons and attach with 4 x M8 bolts, plus additional screws if required, see Figs. 8 and 9. Ensure that the mains cable is fed through the rectangular cut out and is not trapped between the outer cover box and the floor. It is recommended to use 4 additional screws at the ends of the mounting brackets.

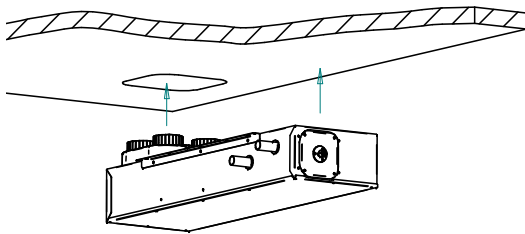

Fig. 8 - Positioning the Heater

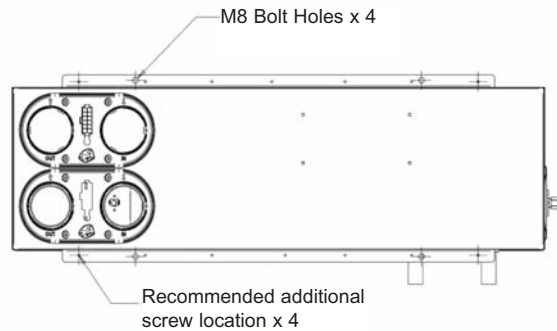

Fig. 9 - Securing the Heater



### Step 3: Securing the Flues

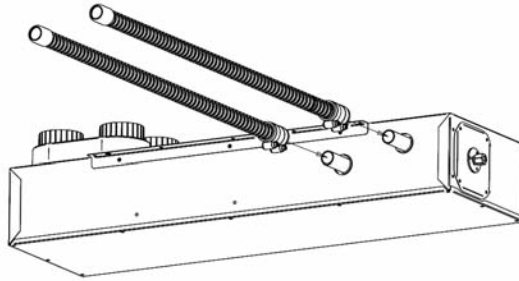

Fig. 10 - Attaching Flues

Push on the ends of the flues with the blue adaptor to the pipes on the underside of the Space Heater ensuring they are fully pushed on, and secure with supplied hose clips (see Fig. 10).

### Step 4: Mounting the Flues

When mounting the combustion air inlet flue and exhaust flue, they should ideally run downwards from the heater to their open end to allow any condensation to drain out. The open ends should be angled downwards to prevent rain from entering. Care should be taken to route exhaust flues around chassis members and avoiding gas pipes and wires.

The flues should otherwise be kept as straight as possible.

The exhaust flue **must** be positioned to avoid contact with combustible materials, such as the caravan floor or skirt. Brackets can be used to ensure the hot flue has a safe gap around it.

**Please note:** The exhaust flue should be positioned at the side or the rear end of the vehicle. The open end of the combustion air flue must be at least 500mm away from the open end of the exhaust flue and pointing in the same direction.

The combustion air inlet flue is attached to the underside of the floor with two brackets. The exhaust flue should be secured in the same way. Clip the bracket around the flue and use two screws (No.8 x  $\frac{3}{4}$ " ) to attach each bracket to the floor as per Fig.11 below:

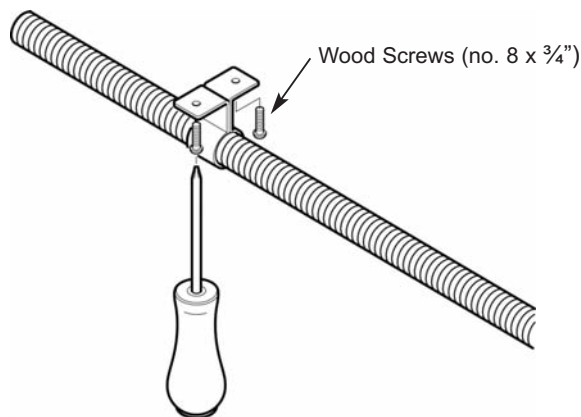

Fig. 11 - Secure Flue Brackets

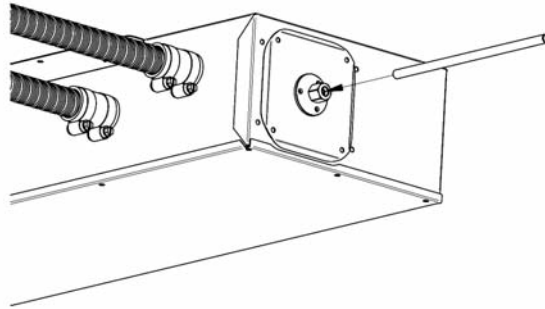

Fig. 12 - Connect to Gas Supply

### Step 5: Connect to Gas Supply

The appliance **must** be installed by a competent person in accordance with the installation instructions and comply with any relevant regulations in the country where the appliance is installed.

The Space Heater is supplied with a compression nut and olive for 8mm (5/16") pipe. The supply pipe **must** be checked and be free from dirt or other particles before connection to the compression joint on the space heater. The supply pipe **must** be routed so that the appliance can be removed for servicing. A gas shut-off valve **must be** located in the vicinity of the space heater and all connections should be kept to a minimum. It is recommended that a gas pressure test point is fitted to the inlet of the appliance.

When the gas line is complete, all joints should be tested for leaks using air to measure the pressure drop, leak detection fluid can then be used. **Never with a naked flame.**

The gas pressure **must be** verified at the pressure test point.

**Please note:** The operating pressure for the gas supply in caravans and motorhomes **must** be 30mBar.

### Step 6: Fitting Hot Air Ducts

To fit the ducting, push it onto the 'outlet' ports, where it will snap into place (see Fig. 13).

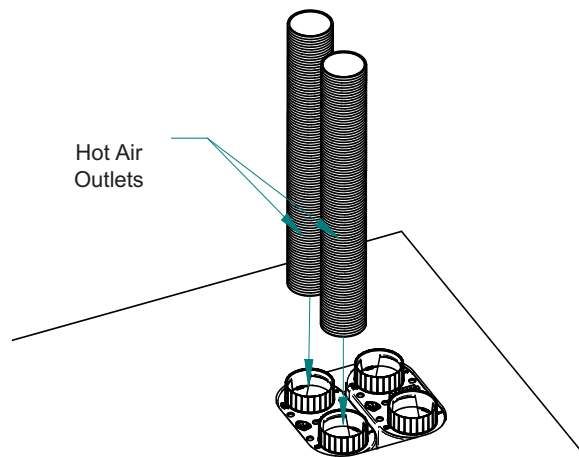

Fig. 13 - Fitting Hot Air Ducts

When fitting the air ducts, ensure that the outlet ducts are fitted to the hot air out (red) fitting and the inlet ducts are connected to the cold air in (blue) fitting.

**Important:** At least one hot air outlet vent is to be permanently open on each branch of ducting. The hot air duct should not be fed into the centre branch of a tee fitting, as per Fig. 14.

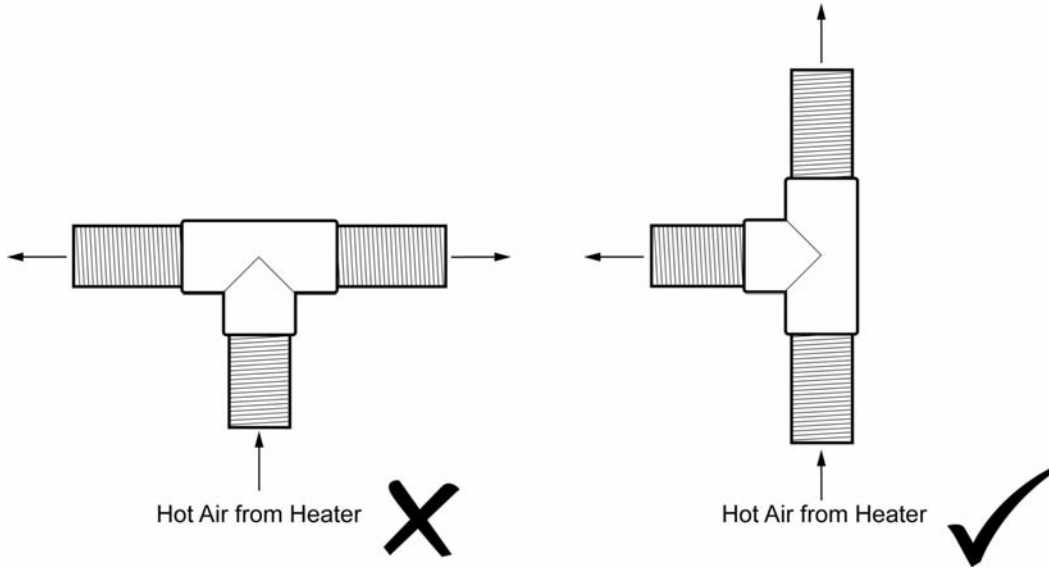

Fig. 14 - Tee Fitting Orientation

### Step 7: Fitting Cold Air Supply

The Whale® Space Heater **must** be adequately supplied with cold air. If the heater is installed in a bed box or another confined space, either vents into the area **must** be fitted or ducting used to supply the heater with cold air. If a vent is fitted, it **must** be no smaller than one designed for use with 60mm ducting. If ducting is fitted it should supply air from the living space of the vehicle. To fit the ducting, push it onto the cold air inlet ports, where it will snap into place (see Fig. 15).

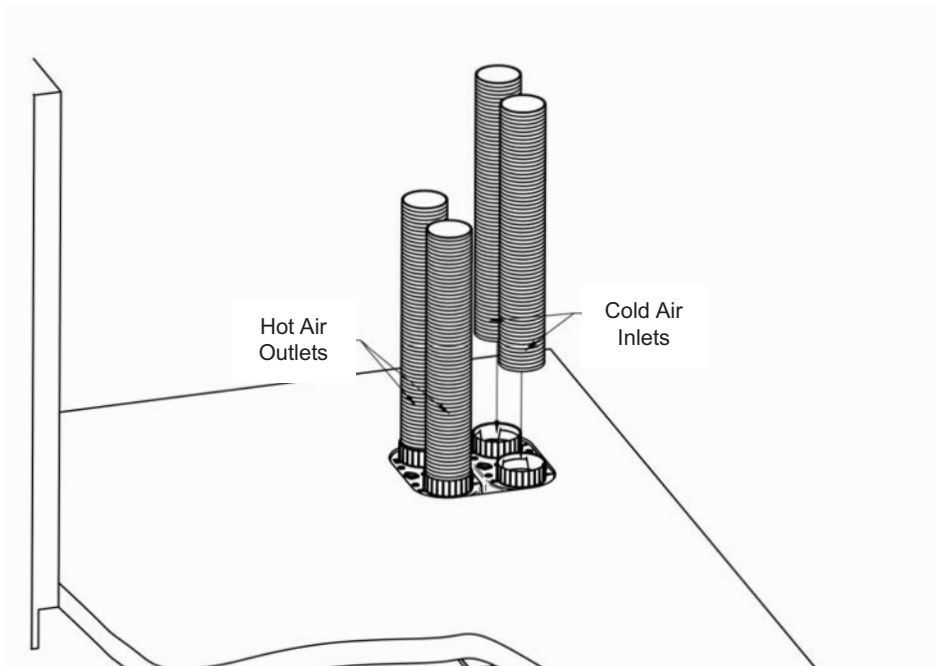

Fig. 15 - Fitting Cold Air Ducts

## Step 8: Mounting of Whale® Control Panel

When mounting the Whale® control panel, find a suitable, convenient and accessible position. For good temperature control, select a position away from draughts and approximately 1.5m above the floor. Ensure suitable access for wiring loom connection and cable. Note that the cable supplied with the retail heater to connect the control panel to the space heater is 3.5m long. The minimum depth behind the panel for wiring **must** be 40mm. If using a control panel specific to the manufacturer of the vehicle the electrical connections **must** be made in accordance with step 9.

The control panel requires a cut out 95mm wide x 42mm high. Feed the wires through the cut out in the wall and locate into desired position. Secure with 4 screws (No.4 x 3/4), then clip on the surround frame (see Figs 16 to 18).

In some instances, it may be necessary to make the wiring connections in step 9 before securing the control panel to the wall.

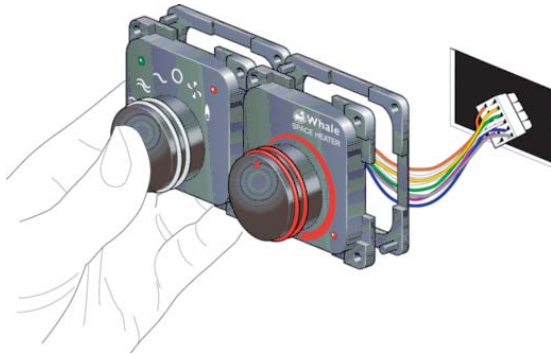

Fig. 16 - Insert Control Panel



Fig. 17 - Secure Control Panel



Fig. 18 - Installed Control Panel

## Step 9: Electrical Connections 12V

### Manufacturer Installation

**WARNING:** Always disconnect the appliance from the power supply prior to working on electrical components. The space heater and control panel come complete with electrical connectors fitted.

The Whale® Space Heater and Control Panel are designed to be integrated into the caravan's wiring loom. The Space Heater is provided with a JST VL series 12 way socket and the control panel with JST VL 6 and 3 way sockets, 9 wires are required to connect the space heater to the control panel, and 12V d.c. (red) and 0V d.c. (white) power supply are to be connected to the 12 way socket at the heater as shown in tables 1 and 2 and Fig. 19.

**Please note:** The heater **must** be installed in-line with a 5 Amp automotive fuse.

**Table 1: Connections at Space Heater**

Terminal Number	Description	Wire Colour
1	Switch common	Brown
2	0V to Switch panel	Black
3	Fan Switch	Yellow
4	Electric 1 Switch	Green
5	Electric 2 Switch	Grey
6	Electric 3 Switch	Pink
7	Burner Switch	Blue
8	Burner LED	Orange
9	Lockout LED	Violet
10	12V supply	Red
11	0V supply	White

**Table 2: Connections at Control Panel:**

Connector	Terminal Number	Description	Wire Colour
<b>6 Way connector</b>	1	Switch common	Brown
	2	Burner Switch	Blue
	3	Fan Switch	Yellow
	4	0V to Switch panel	Black
	5	Burner LED	Orange
	6	Lockout LED	Violet
<b>3 Way connector</b>	1	Electric 1 Switch	Green
	2	Electric 2 Switch	Grey
	3	Electric 3 Switch	Pink

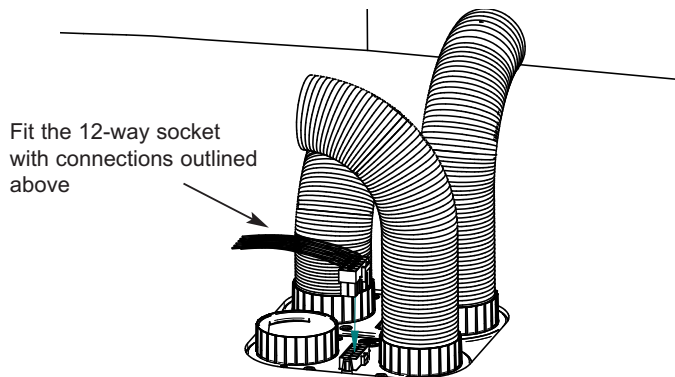

**Fig. 19 - Connect 12V d.c. to Interface Plate**

### Step 10: Electrical Connection 230V

The appliance should be installed in accordance with the installation instructions and comply with any relevant regulations in the country where the appliance is installed. Electrical installation **must** be carried out by a suitably qualified electrician. The electrical supply **must** be connected to a 13 Amp fused spur provided with an all-pole disconnection and the appliance **must** be earthed.

#### Manufacturer Installation Example

The mains supply cable is supplied with a JST LP series socket as shown in Fig 20 (terminal pins are JST slim-61T-2.0) and must be mounted in a housing with strain relief to prevent accidental disconnection and prevent access to the connector.

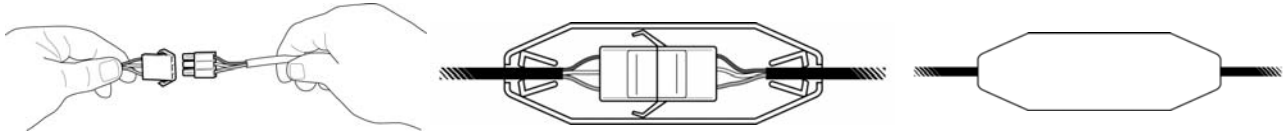

Fig. 20 - Mains Electrical Connection

**Please note:** If the supply cable is damaged, it **must** be replaced by the caravan/motorhome/cable manufacturer or a Whale® Approved Service Centre or Technician.

#### Warning:

The appliance **must not** be supplied through an external switching device, such as a timer, or a circuit that is regularly switched. This is to avoid an inadvertent resetting of the thermal cut out.

N.B. Ensure that the Space Heater is not located immediately below the electrical supply socket.

#### Completed installation:

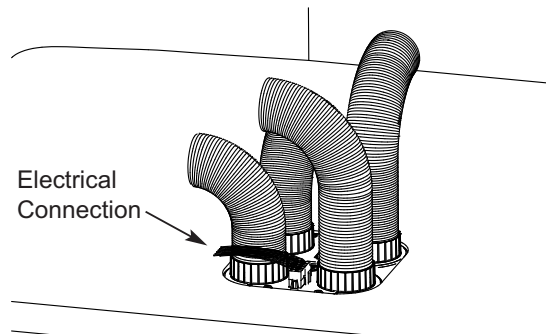

Fig. 21 - Completed Installation

**Please note:** After completing the installation, carry out a full function check including gas soundness to ensure the appliance has been installed and operates correctly. The gas soundness check **must** be carried out by an accredited LPG gas engineer and a test certificate issued.

## 7. INSTRUCTIONS FOR USE

To the User:

Read the following instructions carefully.

### **Observe all warnings.**

In the unlikely event of leaks in the gas system, or if there is a smell of gas:

- Extinguish all naked flames
- Do not operate any electrical switches
- Turn off all gas appliances
- Open windows and doors for ventilation
- Do not smoke
- Shut off gas connection

Get the system thoroughly checked by a Whale® Approved Service Centre / Technician.

The space heater shall not be operated in the following situations:

- When refuelling the vehicle, the vehicle towing the caravan, or other appliances
- When the vehicle in which the heater is installed is in a confined space such as a garage.

This appliance is not intended for use by persons (including children) with reduced physical, sensory or mental capabilities, or lack of experience and knowledge, unless they have been given supervision or instruction concerning use of the appliance by a person responsible for their safety. Children should be supervised to ensure that they do not play with the appliance.

Ensure that a minimum of one of the hot air outlet vents is permanently open on each branch.

When using gas, the combustion air flue and outlet openings for the products of combustion (exhaust flue) **must never be obstructed**. They **must** be checked regularly, and if necessary cleaned by the user (e.g. in winter, snow shall be removed from the combustion outlet and air intake).

Where the open end of the exhaust flue terminates, three sides of the under-floor space **must** be kept open and not obstructed, and not contain through-floor ventilation openings.

The heater, its gas supply and flues for the products of combustion are to be inspected in accordance with national regulations or if these do not exist, the manufacturer's recommendations, however, it is advised that this **must** be done at least annually.

The Whale® Space Heater should be checked periodically by a Whale® Approved Service Centre / Technician, or competent person, at least annually. This **must** be completed according to the practice in the country where it is used and according to the Whale® instructions. We recommend annual testing of gas soundness and combustion by an accredited LPG gas engineer. The appliance contains ESD sensitive components and therefore should only be opened by a Whale® Approved Service Centre / Technician (contact Whale® Support).

When using operating switches provided by the installer or manufacturer, they are responsible for providing user instructions and identification of symbols on the control panel. The inlet vents of the heater **must never** be blocked and at least one hot air outlet vent is to be permanently open on each branch.

## OPERATING INSTRUCTIONS



Fig. 22 - Control Panel

For operation of the heater, a 12V d.c. supply must be connected at all times. To operate the heater's electric elements, it must also be connected to a suitable 230V a.c. supply.

Symbol	Setting	Description
	OFF	Heater will be off. Once the heater is switched off it will purge for 3 minutes to allow the components to cool down
	Fan	Heater will operate on fan only
	Gas	Heater will operate on gas only. There will be a pre purge time of around 30 seconds before ignition. When the gas is lit, the green LED will be illuminated. If the heater fails to light for any reason, the red LED will flash. Refer to the trouble shooting guide (section 9)
	Electric Low	Heater will operate at 500W on electric setting
	Electric Medium	Heater will operate at 1kW on electric setting
	Electric High	Heater will operate at 2kW on electric setting
	Boost / Dual	The heater will operate on gas and electric simultaneously. Depending on the temperature inside the heater, it may run on 1kW, 0.5kW or 0kW electric. When the gas is operating, the green LED will be lit. If there are any problems with operation, the red LED will flash, refer to the trouble shooting guide (see section 9)

**Note:** The electric elements will still operate if the appliance is in gas ignition lockout.

### Adjusting The Room Temperature:

Turn the temperature control knob clockwise to increase and anti-clockwise to reduce the room temperature. The heater will automatically turn itself on and off to maintain the desired ambient temperature.

Note that the controls incorporate a frost protection setting. This can be activated by turning the temperature control knob fully anti-clockwise.



## 8. MAINTENANCE

If the heater has not been used for some time, dust may have settled inside the heater and the ducting. Run the heater on the "Fan only" setting until it clears. The outside of the appliance should not normally require cleaning. If it does, isolate the electrical supplies and wipe down with a soft, damp cloth only. Allow to fully dry before reconnecting the electrical supplies.

The Whale® Space Heater **must** be checked periodically by a Whale® Approved Service Centre / Technician, or competent person, at least annually. This **must** be completed according to the practice in the country where it is used and according to the Whale® instructions. We recommend annual testing of gas soundness and combustion by an accredited LPG gas engineer. The appliance contains ESD sensitive components and therefore should only be opened by a Whale® Approved Service Centre / Technician (contact Whale® Support).

## 9. TROUBLESHOOTING

The heater is equipped with an electronic diagnostic system which will detect fault conditions ranging from poor gas or d.c. supply to internal heater malfunctions. In the unlikely event of a failure, the red light on the control panel will flash a number of times, pause, and repeat until switched off. Count the number of flashes and refer to the table below.

Number of Flashes	Fault	Remedy
1	No flame detected	Check gas supply making sure there is gas in the bottle. Tip: try lighting the hob/cooker to confirm if there is gas. Check isolators and ensure there is no blockage in the gas line. Ensure propane is used at temperatures below +5°C. Clear lockout as described below.
2	Overheat	Check the air ducts and vents are not blocked or restricted. We recommend you wait at least 5 to 10 minutes to allow the heater to cool before clearing lockout as described below. The Space Heater will run a 3 minute post lock out purge.
3	Low/high supply voltage	Minimum operating voltage is 10V d.c., maximum is 15V d.c., when measured at the heater. Check battery voltage. If between 10V d.c. and 15V d.c., check connections between heater and battery. Check alternator or external battery charging. Clear lockout as described below. Note: When connected to mains, the low voltage lock out is 11.5V d.c.
4	Combustion air fault	Check combustion air inlet flue and exhaust flue for blockages. Note: Do not blow high pressure air through flues.
5	Other / internal fault	Attempt to clear lockout as shown below. If this fails, contact a Whale Approved Service Centre / Technician.

### Gas Lockouts

Gas lockouts **must** be cleared by turning the selector knob from gas on (flame) position to off position then back to the on position. The complete sequence of switch movements **must** be completed within 2.5 seconds for a lockout to be successfully cleared. If there is air in the gas line, e.g. after a gas bottle change, the space heater may require several attempts before it lights. Lockouts can also be cleared by switching to the 'fan only' position and then back to 'on' within this 2.5 second period.

### Other Lockouts

If the lockout is caused when the unit is operated on electric, the lockout can be cleared by turning the selector knob from electric 'on' position to 'off' position then back to the 'on' position. The complete sequence of switch movements must be completed within 2.5 seconds for a lockout to be successfully cleared.

**Note:** A cycling of the power supply to the unit will not clear a lockout. Some gas lockouts, e.g. ignition lockout and combustion air faults will still permit use of the appliance in electric only operation.

If the problem persists contact **Whale Support on +44 (0)845 217 293.**

## 10. WINTERISING

When using the heater in winter ensure that the flues are not blocked by snow or fallen leaves etc. When the Space Heater is not going to be used for a long period of time, we recommend that the open end of the combustion air and exhaust flue are covered to prevent ingress of leaves etc.

## 11. SERVICE SUPPORT DETAILS

For installation or serviceable parts advice please contact **Whale® Customer Support:**

**Tel:** +44 (0)845 217 2933

**Email:** info@whalepumps.com

Please note that by contacting Whale Support you will be indicating your consent to receive product updates, recall information, help guides and appropriate marketing messages from us via post, email or telephone unless you indicate an objection to receiving such messages.

## 12. EU DECLARATION OF CONFORMITY

Description of Equipment: **Gas and Electric Space Heater**

### Manufacturer's Declaration

We hereby declare, under our sole responsibility, that the above equipment complies with the provisions of the following EC Directives.

Gas Appliance Directive 2009/142/EC on the approximation of the laws of the Member States relating to appliances burning gaseous fuels.

Low Voltage Directive 2006/95/EC on the harmonization of the laws of the Member States relating to electrical equipment designed for use within certain voltage limits.

Electromagnetic Compatibility Directive 2009/19/EC, on the approximation of the laws of the Member States relating to automotive electromagnetic compatibility.

CE mark first affixed: July 2012

Basis on which conformity is declared

The above equipment complies with the protection requirements of the EMC Directive and the principal elements of the safety objectives of the Low Voltage Directive

Please contact Whale® if further details are required.

Signed

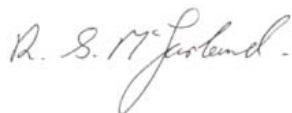

Stanley McFarland  
Engineering Director

### 13. PATENTS AND TRADEMARKS

The Whale® Space Heater is patent pending protected by the following patent and design registration applications:

UK Patent application number No.s 12022425.3, 0902533.9 and 0915825.4.

Whale® is a registered trademark of Munster Simms Engineering Ltd (also trading as Whale®).

### 14. WARRANTY

The Whale® Space Heater is covered by a standard 3 year warranty, unless otherwise stated in your van's manual. Please complete the enclosed warranty card and return to Whale.

For warranty details, please see the enclosed warranty statement.

© Copyright Whale® 2012 - All rights reserved. Whale® is a registered trademark of Munster Simms Engineering Limited, Bangor, Northern Ireland, trading as Whale®. Whale's policy is one of continuous improvement and we reserve the right to change specifications without prior notice. Illustrations are for guidance purposes only.

Munster Simms Engineering Ltd.  
Old Belfast Road, Bangor, N. Ireland BT19 1LT

Tel: +44 (0)28 9127 0531  
Fax: +44 (0)28 9146 6421

[www.whalepumps.com](http://www.whalepumps.com)  
Email: [info@whalepumps.com](mailto:info@whalepumps.com)

